

## Digital Undercounter ecostore HP Concept Freezer Counter - 6x1/3 Drawers (60Hz)

ITEM # \_\_\_\_\_

MODEL # \_\_\_\_\_

NAME # \_\_\_\_\_

SIS # \_\_\_\_\_

AIA # \_\_\_\_\_

**710382 (EK2FBCCH)**

 6x1/3 drawer Freezer  
 Counter, -22-15°C, AISI 304  
 (R404A), UK plug - 60 Hz

### Short Form Specification

**Item No.** \_\_\_\_\_

AISI 304 stainless steel panels, AISI 430 bottom panel, galvanized back panel. Worktop thickness 50mm. N. 6X1/3 drawers. Built-in refrigeration unit. Automatic defrost. Operating temperature: -15-22°C. R404A gas in refrigeration circuit.

### Main Features

- Adjustable temperature range from -15 °C to -22 °C to suit meat, fish and dairy storage requirements.
- 0mm clearance installation space: tower configuration cooling unit guarantee performance with frontal ventilation only; this unique solution allows installation against the wall or side by side with other appliances, even on the cooling unit side to maximize the use of kitchen space.
- Combination of doors and drawers to suit any configuration needed, with the possibility to change the configuration on site. Right cooling unit available on request.
- Frontal and easy access to all components in the cooling unit.
- Anti-tilt runners accept GN 1/1 containers.
- Self closing stainless steel doors (< 90°).
- Certified safety CE requirements.
- Prearranged to fit RS485 port to facilitate connection to a remote computer and integrated HACCP systems.
- Equipped with forced air circulation system for rapid cooling and temperature distribution within the cell.
- Freezer compartment designed to accept GN1/1 containers.
- Combination of doors and drawers to suit varying needs, with the possibility to change the configuration on site.
- Digital control panel with temperature display.
- Forced air circulation for rapid cooling and an even temperature distribution.
- Digital white-digit display with internal temperature display and setting, manual activation of defrost cycle and turbo frost cycle (to rapidly cool warm loads).
- Tropicalized unit.

### Construction

- Worktop in AISI 304 Stainless steel with a 50 mm profile.
- If needed, working top can be removed for easier handling during installation (in case of narrow doors).
- Anti-drip profile on stainless steel worktop edge.
- Interior base with rounded corners, pressed from a single sheet.
- Ease of cleaning and high hygiene standards thanks to the rounded internal corners, the easily removable runners, grids and air conveyors.
- Internal structure with 15 charging positions (3 cm pitch) available to host GN 1/1 grids, ensuring higher net capacity and a greater storage space.
- Internal and external doors, front and side panels and removable worktop in AISI 304 Stainless steel.
- Built-in refrigeration unit.
- Developed and produced in ISO 9001 and ISO 14001 certified factory.
- Fault code display.
- Pre-arranged for drain-pipe.
- Excellent space optimisation thanks to the compact

**APPROVAL:** \_\_\_\_\_

dimensions.

- Built-in compressor to suit operating conditions.
- Full stainless steel construction. Internal structure and worktop in AISI 304 Stainless steel.
- Rounded internal corners for ease of cleaning.
- Mounted on Stainless steel adjustable legs to give 150 mm clearance for ease of cleaning.
- Access to all components from the front.
- Extractable cooling unit to facilitate maintenance.
- Mounted on stainless steel feet to give 150 mm (-5/+50 mm) clearance for ease of cleaning the floor.
- External bottom panel in stainless steel.
- External back panel in galvanized steel.
- Internal dimension of the drawers: - models with 2 1/2 drawers: 1st drawer (top drawer) 203x302x521 / 2nd drawer 223x302x521 (HxWxD) - models with 3 1/3 drawers: 1st drawer (top drawer) 98x302x521 / 2nd and 3rd drawers 118x302x521 (HxWxD) - models with 1/3+2/3 drawers: 1st drawer (top drawer) 98x302x521 / 2nd drawer 333x302x521 (HxWxD)

### User Interface & Data Management

- Fully compliant HACCP digital control: when temperature exceeds critical limits, acoustic and visual alarms are activated. Up to two months of event are kept in memory.
- Easy serviceability thanks to the intuitive control panel with access via app.
- Integrated RS485 port to facilitate connection to a remote computer and integrated HACCP systems.

### Sustainability



- Fitted with 90 mm thickness of cyclopentane insulation for best insulating performance (thermal conductivity: 0,020 W/m\*K) and lowest environmental impact (GWP=3).
- Hot gas automatic evaporation of defrost water.
- CFC and HCFC free (ecological refrigerant type: R404a, gas in foam: cyclopentane).
- Removable triple-chamber balloon magnetic gasket to improve insulation and reduce energy consumption and ease of cleaning.

Front



Side

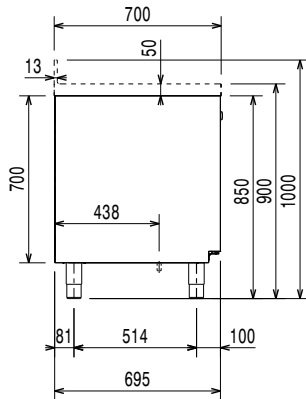

EI = Electrical inlet (power)

Top



## Electric

Supply voltage:	220-230 V/1 ph/60 Hz
Electrical power, max:	0.5 kW
Defrost Power:	0.57 kW
Plug type:	UK-13A

## Key Information:

Net Volume:	94 lt
Door hinges:	
External dimensions, Width:	1345 mm
External dimensions, Depth:	700 mm
External dimensions, Height:	900 mm
Internal Dimensions, Width:	798 mm
Internal Dimensions, Depth:	560 mm
Internal Dimensions, Height:	550 mm
Net weight:	119 kg
Shipping volume:	1.13 m <sup>3</sup>
Depth with doors open:	1110 mm
Height adjustment:	0/0 mm
Gross capacity:	290 lt

## Refrigeration Data

Control type:	Digital
Refrigeration power at evaporation temperature:	-30 °C
Min/Max internal humidity:	
Operating temperature min.:	-15 °C
Operating temperature max.:	-22 °C
Compressor power:	3/4 hp
Operating mode:	Ventilated
Insulation:	90 mm (Cyclopentane)

## ISO Certificates

ISO Standards:	ISO 9001; ISO 14001; ISO 45001; ISO 50001
----------------	---

## Sustainability

Current consumption:	3.5 Amps
Refrigerant type:	R404A
GWP Index:	3260
Refrigeration power:	528 W
Refrigerant weight (unit 1):	340 g
Energy Class (EU Reg. 2015/1094):	